



HTL Power-Pro Torque Pump

The HTL Worldwide Power-Pro Hydraulic Torque Pump is available with a multi-tool manifold (as pictured) allowing up to four tools to be used simultaneously ensuring equal, parallel closure of flanges; alternatively the pump can be delivered with a single tool manifold. The pump incorporates a compact solenoid valve system which ensures reliability whilst remaining lightweight and portable. The highly ergonomic design ensures ease of use for the operator; ultimately increasing performance.

Features and Benefits

- ✓ Multi-tool manifold as standard
- ✓ Solenoid valve system
- ✓ Protective frame design
- ✓ Robust hand control
- ✓ Precision, calibrated pressure gauge
- ✓ Oil level sight glass



What Is Included

Each pump despatched is ready to use and complete with:

- ✓ Full calibration certificate
- ✓ Letter of Conformity
- ✓ Spare parts list
- ✓ Operating instructions
- ✓ HTL Worldwide Pro-46 Hydraulic Oil
- ✓ Twin line hose assembly (custom lengths available)



Twin Line Hoses

Twin line hoses are available in all lengths to specifically suit your needs.



Technical Information

Model	Power Type	Weight	Reservoir		Frame	Power Required	A		B		C	
			Kg	Litres			Gallons	mm	Inch	mm	Inch	mm
Power-Pro Air	Air	32	9	9	Yes	50 CFM	408	16.1	298	11.7	531	21.0
Power-Pro 110	Electric	32	9	9	Yes	110v	439	17.3	298	11.7	531	21.0
Power-Pro 220	Electric	32	9	9	Yes	230v	439	17.3	298	11.7	531	21.0

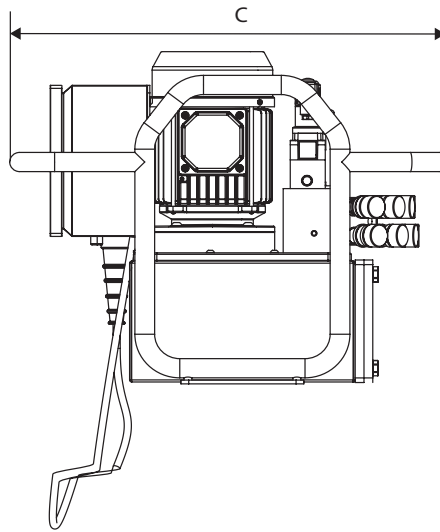
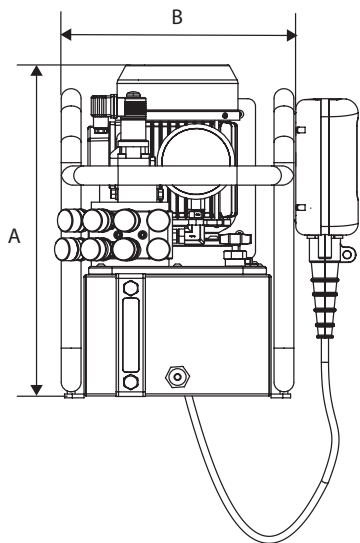
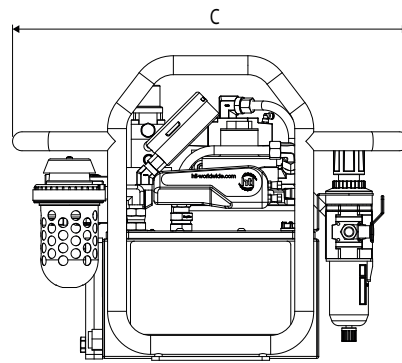
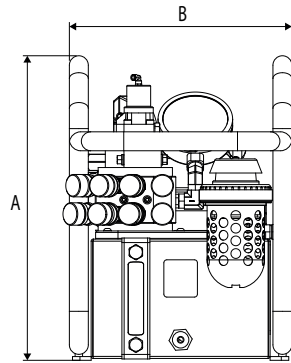

PLEASE NOTE: Figures provided are for guidance only, please refer to individual tool charts. All data is given in good faith and without acceptance of responsibility on the part of HTL.

INDUSTRY LEADERS IN CONTROLLED BOLTING, FLANGE WORKING AND PORTABLE MACHINE SOLUTIONS



HTL Australasia Pty Ltd
 466 Victoria Road
 Malaga, WA 6090
 Western Australia

Telephone: +61 (0) 8 9249 3980
 Email: info@htl-australasia.com
 Visit: www.htl-australasia.com

