



# Hands Free Bolting Back-Up Nut

HTL would like to introduce the Hands Free Bolting's revolutionary new Back-Up Nut.

The **Patented** Back-Up Nut is designed to dramatically improve tool operator safety and assist in preventing injuries caused by dropped objects. This simple yet innovative patented design ensures any one of a wide range of bolting tools can be held in place during operation allowing the operator Hands Free Bolting whilst the tool is in use, dramatically reducing the risk of incident.

The Back-Up Nut can be used with a wide variety of bolting tools including hydraulic torque wrenches, offset gear boxes and drives, spanners, back-up spanners and nut splitters.

Available to fit a range of stud sizes between M12 and M76 as well as  $\frac{1}{2}$ " to  $2\frac{3}{4}$ ".

## Features and Benefits

- ✓ Dramatically improves operator safety
- ✓ Eliminates dropped objects
- ✓ Supports the tool during the placing operation
- ✓ Cost effective safe solution
- ✓ Allows a hands free bolting operation
- ✓ Secures a wide variety of equipment
- ✓ Custom Branding available



# Technical Information

Part No.	Bolt Size	A (mm)	B (mm)	C (mm)	Weight (kg)
A-1-01	1/2"	80	55	25.4	0.2
A-1-02	5/8"				
A-1-03	3/4"				
A-1-04	7/8"				
A-1-05	1"				
A-1-06	1 1/8"				
A-1-07	1 1/4"				
A-1-08	1 3/8"				
A-1-09	M12				
A-1-10	M16				
A-1-11	M22				
A-1-12	M24				
A-1-13	M27				
A-1-14	M30				
A-1-15	M33				
A-1-16	M36				
A-2-01	1 1/2"	123	84	25.4	0.4
A-2-02	1 5/8"				
A-2-03	1 3/4"				
A-2-04	1 7/8"				
A-2-05	2"				
A-2-06	2 1/4"				
A-2-07	M39				
A-2-08	M42				
A-2-09	M45				
A-2-10	M48				
A-2-11	M52				
A-2-12	M56				
A-2-13	M60				
A-3-01	2 1/2"	200	140	25.4	0.95
A-3-02	2 3/4"				
A-3-03	M68				
A-3-04	M72				
A-3-05	M76				

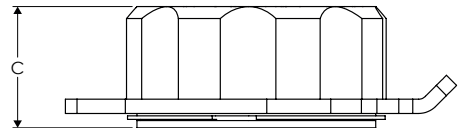
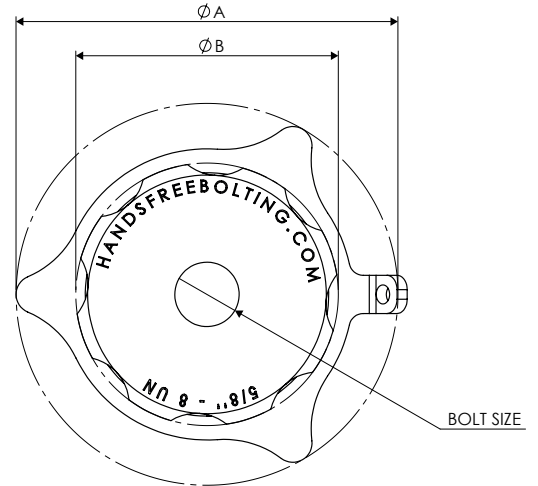

PLEASE NOTE: Figures provided are for guidance only, please refer to individual tool charts. All data is given in good faith and without acceptance of responsibility on the part of HTL.

## EXCELLENCE IN CONTROLLED BOLTING & FLUID POWER SOLUTIONS



HTL Group Ltd  
 45 Colbourne Avenue,  
 Nelson Park Industrial Estate,  
 Cramlington, Northumberland,  
 NE23 1WD

Telephone: +44 (0) 1670 700 000  
 Email: [info@htlgroup.com](mailto:info@htlgroup.com)  
 Visit: [www.htlgroup.com](http://www.htlgroup.com)

