



HD DL Ricci Clamshell Pipe Cutter Range

The robust design of the DL Ricci™ HD or Heavy Duty Clamshell lather series makes them ideal for large diameter heavy wall pipe applications. Each of the machines up to 86" (2184mm) has a height of 6.25" (158.8 mm) and a width of 4.69" (119.1 mm) or 4.81" (122.2 mm). The mass created from these dimensions increases rigidity and helps maintain accuracy during use. These portable split frame machines are capable of pipe cutting and beveling, facing, ID boring and OD turning across a wide range of wall thicknesses.

Features and Benefits

- ✓ 16 Standard models cover a range of 20" (508 mm) to 86" (2,184.4 mm) OD
- ✓ Pneumatic and hydraulic drive options provide increased versatility
- ✓ Fully adjustable heavy duty bearing design provides greater serviceability
- ✓ Stepped and keyed gear clamps equipped with a through bolt provide a positive fit at each assembly joint
- ✓ HD series clamshells accept a wide range of accessories to increase performance and expand capabilities



Included as Standard with each machine

- ✓ Clamshell body
- ✓ Locators & extensions covering the full range
- ✓ Slides
- ✓ Motor & Mounting
- ✓ Air Caddy
- ✓ Tool Kit
- ✓ Manual
- ✓ Shipping crate

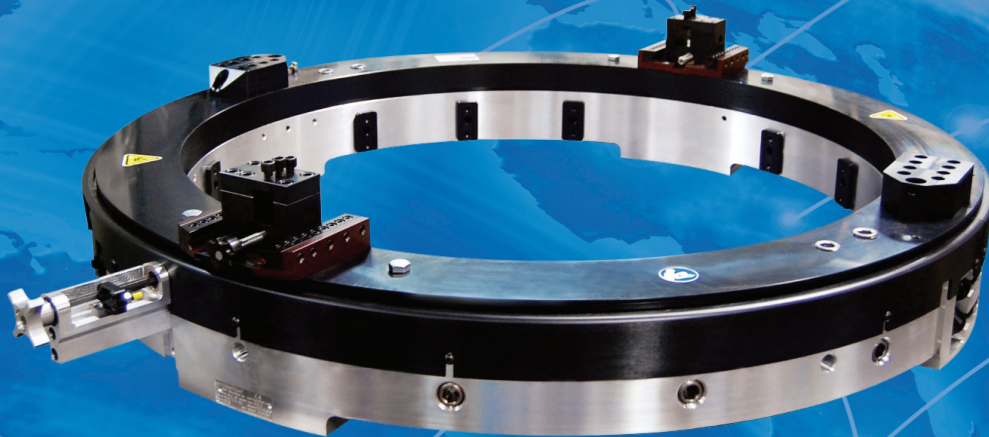
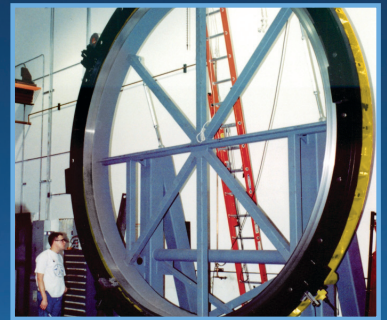

Technical Information

Specification

Model	Mounting Range		Machine ID		A		B		C		D*		Machine Weight	
	mm	Inch	mm	Inch	mm	Inch	mm	Inch	mm	Inch	mm	Inch	Kg	lbs
DLR-HD32	508.0 - 812.8	20.0 - 32.0	838.2	33.0	1076.3	42.4	158.8	6.25	119.1	4.7	215.9	8.5	213.0	469.0
DLR-HD36	609.6 - 914.4	24.0 - 36.0	939.8	37.0	1177.9	46.4	158.8	6.25	119.1	4.7	215.9	8.5	231.08	509.0
DLR-HD39	685.8 - 990.6	27.0 - 39.0	1016.0	40.0	1254.1	49.4	158.8	6.25	119.1	4.7	215.9	8.5	244.3	538.0
DLR-HD43	787.4 - 1092.2	31.0 - 43.0	1117.6	44.0	1355.7	53.4	158.8	6.25	119.1	4.7	215.9	8.5	270.1	595.0
DLR-HD45	828.2 - 1143.0	33.0 - 45.0	1168.4	46.0	1406.5	55.4	158.8	6.25	119.1	4.7	215.9	8.5	278.8	614.0
DLR-HD48	914.4 - 1219.2	36.0 - 48.0	1244.6	49.0	1482.7	58.4	158.8	6.25	119.1	4.7	215.9	8.5	291.9	643.0
DLR-HD50	965.2 - 1270.0	38.0 - 50.0	1295.4	51.0	1533.5	60.4	158.8	6.25	119.1	4.7	215.9	8.5	301.0	663.0
DLR-HD53	1041.4 - 1346.2	41.0 - 53.0	1371.6	54.0	1609.7	63.4	158.8	6.25	119.1	4.7	215.9	8.5	314.2	692.0
DLR-HD54	1066.8 - 1360.8	42.0 - 54.0	1397.0	55.0	1635.1	64.4	158.8	6.25	119.1	4.7	215.9	8.5	318.8	702.0
DLR-HD55	1,092.2 - 1,397	43.0 - 55.0	1422.4	56.0	1660.5	65.4	158.8	6.25	119.1	4.7	215.9	8.5	325.1	716.0
DLR-HD57	1143 - 1447.8	45.0 - 57.0	1473.2	58.0	1711.3	67.4	158.8	6.25	119.1	4.7	215.9	8.5	333.7	735.0
DLR-HD60	1,219.2 - 1,524.0	48.0 - 60.0	1549.4	61.0	1793.9	70.6	158.8	6.25	122.2	4.8	209.6	8.3	337.3	831.0
DLR-HD66	1371.6 - 1676.4	54.0 - 66.0	1701.8	67.0	1946.3	76.6	158.8	6.25	122.2	4.8	209.6	8.3	404.5	891.0
DLR-HD72	1524.0 - 1828.8	60.0 - 72.0	1854.2	73.0	2098.7	82.6	158.8	6.25	122.2	4.8	209.6	8.3	432.2	952.0
DLR-HD80	1727.2 - 2032.0	68.0 - 80.0	2057.4	81.0	2301.9	90.6	158.8	6.25	122.2	4.8	209.6	8.3	482.6	1063.0
DLR-HD86	1879.6 - 2184.4	74.0 - 86.0	2209.8	87.0	2454.3	96.6	158.8	6.25	122.2	4.8	209.6	8.3	506.0	1115.0
DLR-120	212.0 - 308.0	85.9 - 121.5	3124.2	123.0	3486.9	137.3	268.2	10.6	149.4	5.9	209.8	8.3	2857.0	6300.0
DLR-HD180	3658.0 - 4496.0	144.0 - 177.0	4565.9	179.8	4976.9	195.9	306.3	12.1	171.5	6.8	231.9	9.1	4535.9	10000.0

* "D" dimension (or outline) may change with different tooling. Contact consultant for specifics.

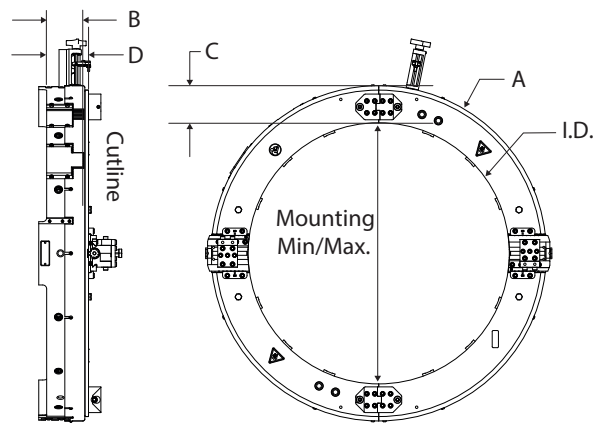

PLEASE NOTE: Figures provided are for guidance only, please refer to individual tool charts. All data is given in good faith and without acceptance of responsibility on the part of HTL.

GLOBAL EXCELLENCE IN CONTROLLED BOLTING



HTL Australasia Pty Ltd
466 Victoria Road
Malaga, WA 6090
Western Australia

Telephone: +61 (0) 8 9249 3980
Email: info@htl-australasia.com
Visit: www.htl-australasia.com

