



MM610i Flange Facer

The MM610i model is an internally mounted lightweight flange facing machine for all types of flange facing, seal groove machining, weld prep and counter boring. The MM610i machine is supplied complete with toolkit including tools and inserts, air filter lubricator and hose connection, all required mounting base and extensions, storage / shipping box, CE certificate, packing list and manual.

Features and Benefits

- ✓ Lightweight construction – for flexible use on-site
- ✓ Quick set independent base - minimising set up time
- ✓ Swivel tool post – for wide range of applications with additional accessories
- ✓ Helical drive for a superior finish
- ✓ Geared continuous groove facing feeds, for gramophone finish (ASME Standard)



MIRAGE
PORTABLE PERFORMANCE

Technical Information

Model	Facing Diameter		Clamping Diameter		Revolutions Per Minute		Tool Post Travel	Weight
	Min	Max	Min	Max	Min	Max		Kg
MM610I	50 mm	610 mm	50 mm	508 mm	20	42	50mm	45

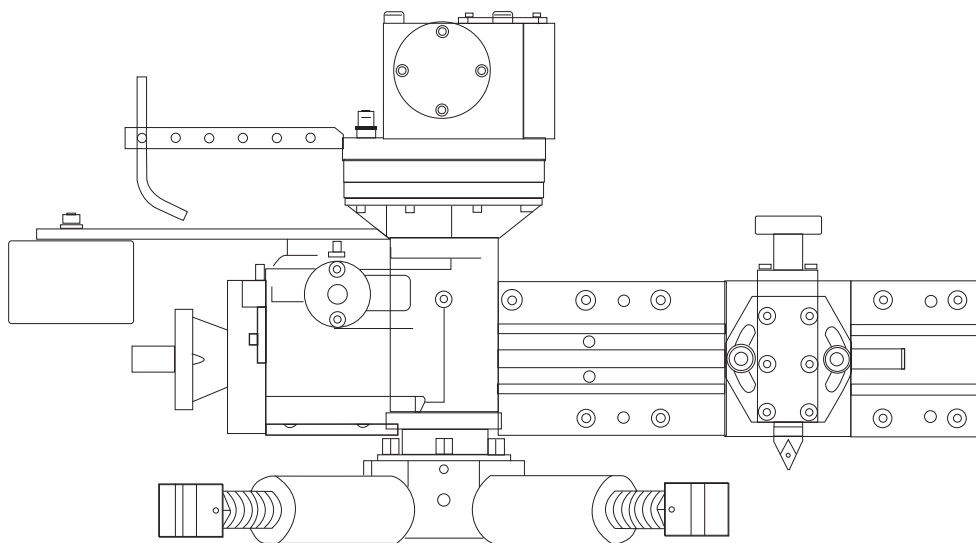

PLEASE NOTE: Figures provided are for guidance only, please refer to individual tool charts. All data is given in good faith and without acceptance of responsibility on the part of HTL.

GLOBAL EXCELLENCE IN CONTROLLED BOLTING



HTL Australasia Pty Ltd
466 Victoria Road
Malaga, WA 6090
Western Australia

Telephone: +61 (0) 8 9249 3980
Email: info@htl-australasia.com
Visit: www.htl-australasia.com

